

STC 氣動式油壓千斤頂推車型

- 推車型設計使用輕便。
- 採用空氣動力泵浦、增加效率。
- 採用合金鋼主軸硬銘處理，主軸均具自動回縮功能。
- 各型號均附墊塊組。

Air Hydraulic Truck Jack

- ※ Trolley design for easy movement.
- ※ Air pump increases efficiency.
- ※ Chrome plated plunger with self-return.
- ※ Saddle sets are included on all models.



STC-30L

STC-50DL

STC-50

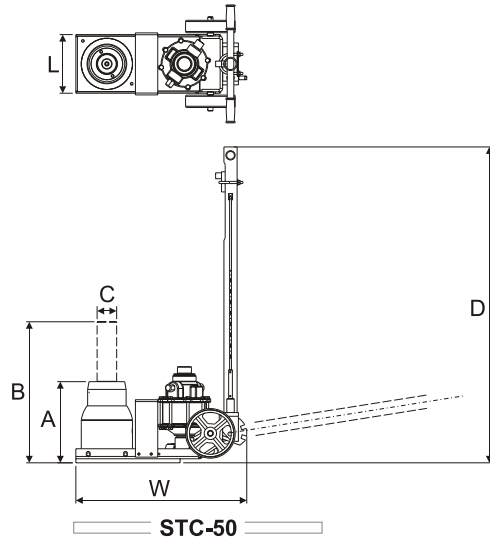
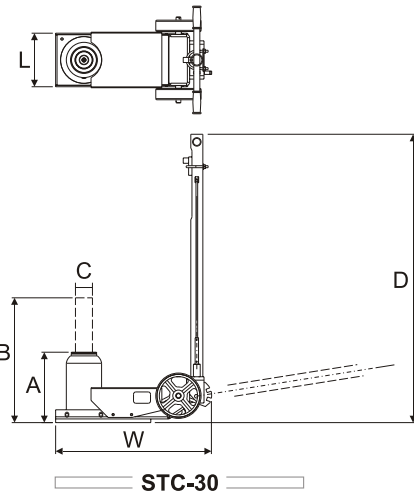

STC-50DL



STC-50

型號 Model Number	能力 Cap. (tons)	揚程 Stroke (mm)	本身高 Coll. Height A (mm)	伸長總高 Ext. Height B (mm)	主軸 Plunger C (mm)	柄高 Handle Height D (mm)	底座尺寸 Base Dimensions L x W (mm)	輔助高度 Auxiliary Height (mm)	使用空壓 Air pressure Rang (kgf/cm ²)	總重 Weight (kg)
STC-30L	30	120	224	350	60	1385	190x570	10,45,80	10-15	45.5
STC-50	50	130	242	375	65	1055	190x570	10,60,120	10-15	58.5
STC-50L	50	130	242	375	65	1390	190x570	10,60,120	10-15	58.5
STC-50L2	50	130	242	375	65	1690	190x570	10,60,120	10-15	58.5
STC-50DL	1 st 50 2 nd 30	140	160	300	∅85/∅55	1385	190x570	10,60,120	10-15	44.4

SD-I 拆胎系列

- 使用方便，操作簡單。
- 適用範圍廣泛。
- 節省人力，提高工作效率。

Tire Separation Series

- ※ Easy to use and operate.
- ※ Apply to application extensively
- ※ Manpower saving and efficiency increasing

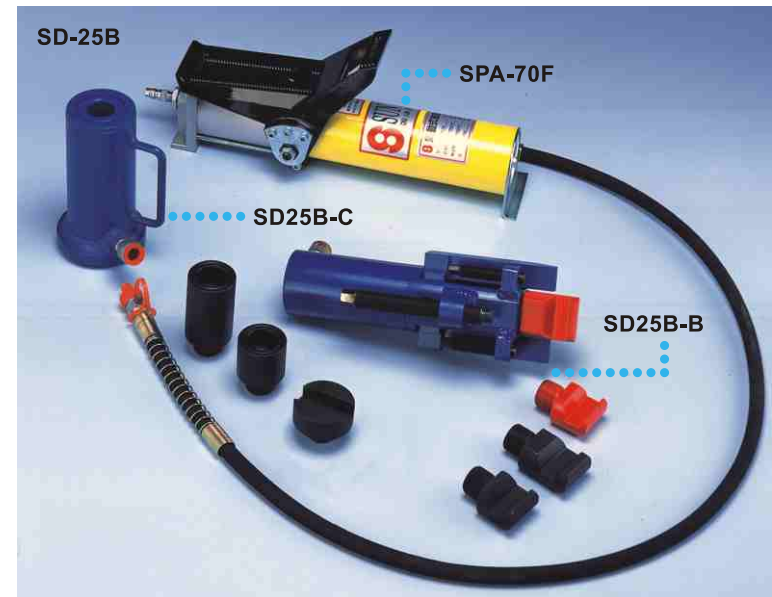

Model Number 型號	Product Name 名稱	Description 適用功能	Tire Range 適用範圍	Air Pressure Range 使用空壓 (kgf/cm ²)	Stroke 揚程 (mm)	Advance 推力 (tons)	Weight 總重 (kg)
SD-20A	輪胎迫擊器 Tire releaser	將輪胎與鋼圈間隙放鬆 To loosen the tire and rim.	8.00 / R16~12.00 / R20	10-15	100	8	22.0
SD-25A	巨型特種輪胎迫擊器 Special tire releaser	將輪胎與鋼圈間隙放鬆 To loosen the tire and rim.	20.00 / R24~30.00 / R25	10-15	100	8	24.0
SD-25B	巨型特種輪胎迫擊器(組) Special tire releaser	免卸鋼圈螺絲，直接車上拆胎 To use on the car, don't take apart the screw.	14.00 / R24 24.00 / R25以上(Above)	10-15	—	—	20.0
SD25B-B	巨型特種輪胎迫擊器(件) Special tire releaser				50	16	7.6
SD25B-C	巨型特種輪胎迫擊器(件) Special tire releaser				100	20	5.0
SPA-70F	氣動泵浦 Air Hydraulic Pumps				Page : 17		7.4