

## SPEGM 油壓引擎泵浦

- 多款油箱容量適用於各種油壓缸。
- 所有泵浦均配有堅固框架，適用於各種惡劣環境。
- 高分流壓力增加使用效率。

### Hydraulic Gasoline Pump

- ※Vary reservoirs for use with a wide range of cylinders and application.
- ※All pumps feature sturdy Roll Cages for use in tough environments.
- ※High by-pass pressure improve productivity on all model.



<b>SPEGM Series</b>
<b>Reservoir Capacity:</b> 8 L
<b>Flow at rated pressure:</b> 0.78-5.5 L
<b>Motor Size:</b> 3.2 kW(4hp)
<b>Maximum Operating Pressure:</b> 700 bar

泵浦型號選擇 Custom build your Pump:  
**SPEGM- 4 8 4 CW**  
1 2 3 4

1. 馬達 4=4hp(3.2kW)	1. Motor 4=4hp(3.2kW)
2. 油箱 (Lx0.26=gal) 8=8L(2.1gal) ★亦可依客戶訂製	2. Reservoir (Lx0.26=gal) 8=8L(2.1gal) ★User can order suitable reservoir.
3. 閥 3=手動三口方向閥 4=手動四口方向閥	3. Valve 3=Manual 3Way 4=Manual 4Way
4. 選配 W=輪子 G=壓力錶	4. Optional W=Wheel G=Pressure gauge

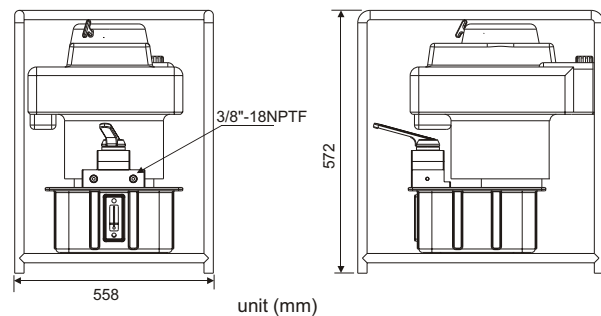

泵浦基本閥型 BASIC PUMP VALVE	適用油壓缸 Used with cylinder		閥作用 Valve Function	
	●	●	●	●
手動三口方向閥 Manual 3 way Valve	●	●	●	●
手動四口方向閥 Manual 4 way Valve	●	●	●	●

型號 Model Number	馬達 Motor Type/ size	輸出流量 Flow Rate		閥作用 Valve Function	噪音值 dBA at Idle and 700bar	重量 Weight
		(L/min)				
		1 <sup>st</sup> stage	2 <sup>nd</sup> stage			(kg)
SPEGM	Honda-4hp	5.5	0.78	Advance/Hold/ Retract	90	54

### 控制閥樣式 Control Valve Type

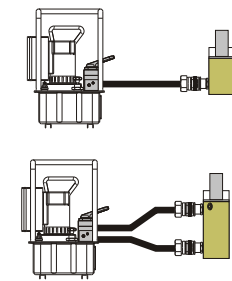

**3口方向閥**  
適用於單動油壓缸  
3 Way Valve  
Are used with single-acting cylinder.

**4口方向閥**  
適用於雙動油壓缸  
4 Way Valve  
Are used with double-acting cylinder.

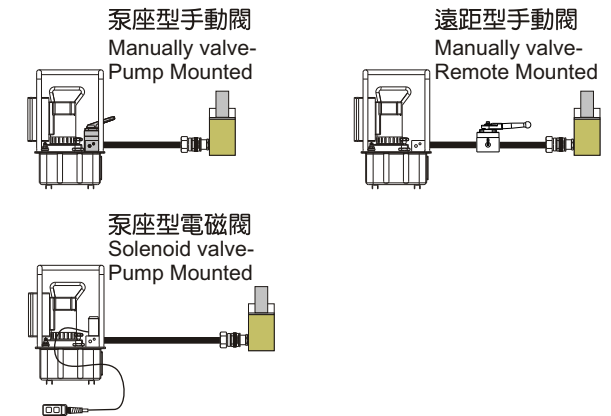

**泵座型手動閥**  
Manually valve-  
Pump Mounted

**遠距型手動閥**  
Manually valve-  
Remote Mounted

**泵座型電磁閥**  
Solenoid valve-  
Pump Mounted

	前進&持壓 Advance & Hold		回縮&持壓或洩壓 Retract & Hold or Release	
	手動時持壓 Manual Hold	電動時持壓 Electric Hold	手動時持壓/ 洩壓 Manual Hold/ Release	電動時持壓/ 洩壓 Electric Hold/ Release
3口方向閥 3 Way Valve				
4口方向閥 4 Way Valve				

大部份SUN RUN 閥類均符合左列操作。SW-700系列或特製品請參考型錄、操作手冊或連絡SUN RUN。

Most SUN RUN valve will be operated as left instruction. SW-700 series or special valve please check to catalog, manual or connect to SUN RUN.

□ :  
三通閥有三個油口：壓力口(P)、油箱口(T)、前進口(A)  
四通閥有四個油口：壓力口(P)、油箱口(T)、前進口(A)、回縮/洩壓口(B)  
位：  
閥體的控制點數量。一個二位閥只能控制液壓缸的前進或回縮。  
要控制油缸維持持壓狀態則需一個位置。

Ways:  
3-way valve has 3 ports: pressure (P), tank (T) and advance (A).  
4-way valve has 4 ports: pressure (P), tank (T), advance (A) and return (B).  
Positions:  
The number of control points a valve can provide. A 2-position valve has the ability to control only the advance or retraction of the cylinder. To be able to control the cylinder with a hold position, the valve requires a 3rd position.

 3 way 2 position	 3 way 3 position N型：中立回油 最常見的是中立回油型，油缸不動，油泵卸載，油溫小。 N : Tandem Center The most common is the Tandem Center. Cylinder ports are blocked, oil from pump goes to tank. This is provides for minimum heat build-up.		
 4 way 2 position	 4 way 3 position N型：中立回油 最常見的是中立回油型，油缸不動，油泵卸載，油溫小。 N : Tandem Center The most common is the Tandem Center. Cylinder ports are blocked, oil from pump goes to tank. This is provides for minimum heat build-up.	 4 way 3 position O型：中立不回油 另一個常見的樣式是中立不回油型，大多用於多油缸進行獨立控制模式。此類型閥不但使油缸不動作，也阻斷泵的油路循環。需要其他方法使泵卸載而避免油溫升高。 O : Closed Center The next most common is the Close Center. That is used mostly for independent control of multi-cylinder applications. This configuration again provides for little to no movement of the cylinder, but also dead-heads the pump, isolating it from the circuit. Use of this type of valve may require some means of unloading the pump to prevent heat build-up.	 4 way 3 position H型：中立聯通 當不需持壓時可使用中立聯通型，當使用二個分開的油壓工具時亦適用例如油壓切斷器和捲揚機。 H : Open Center Open center used when holding is not a requirement, as when running two separate hydraulic tools such as cutters and crimpers.