

SPE-200RI- 超高壓電動泵浦

- 噪音更低、體積輕巧。
- 適合於配套螺栓拉伸器、造船、風電等現場作業。
- 搭配壓力錶以及壓力開關。
- 壓力到達則馬達自動停止且持壓。
- 高低壓二段式自動切換，系統效率高。

High Pressure Hydraulic Electric Pump

- ※ The adoption of a magnet motor reduces the noise remarkably. Lightweight, compact, and easy to transport. Ideal for site work such as shipyard and civil engineering construction.
- ※ The durability has been improved while the performances are maintained.
- ※ A pressure gauge and a pressure switch are included in each model.
- ※ Motor auto stop working and hold pressure as reach setting pressure.
- ※ Automatic high-low pressure switching for improved work efficiency.

*壓力錶以及壓力開關為SPE-200RI-專用，如需搭配其它系列產品混用請諮詢本公司。

*The pressure gauge and switch are exclusive to the SPE-200RI-series. Consult us when them with other series.

電泵型號選擇：Custom build your Electric Pump:

SPE-200RI- 2 1 4 3 C

1.馬達 200RI=0.625HP(0.5kw)	1.Voltage 200RI=0.625HP(0.5kw)
2.電壓/安培 1=110V/12A 2=220V/7A	2.Voltage/A 1=110V/12A 2=220V/7A
3.相數 1=1ph	3.Phase 1=1ph
4.油箱 4=4L	4.Reservoir 4=4L
5.閥門樣式 3=手動三口二位控制閥	5.Valve 3=3way/ 2position Manual Valve
6.配件 C=線控裝置 G=油壓錶	6.fitting C=Remote control G=Pressure Gauge

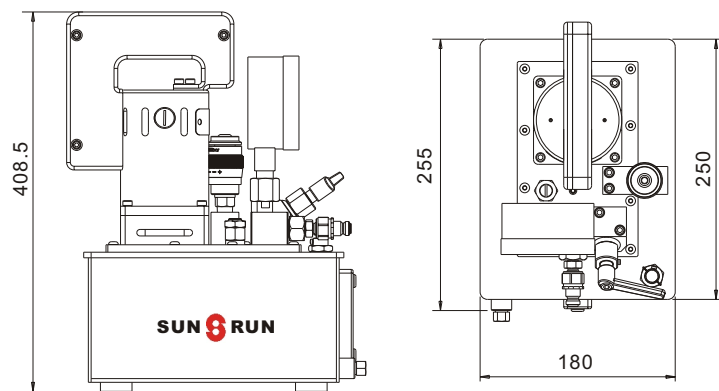
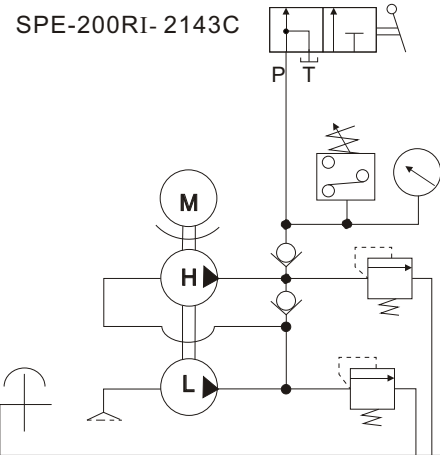

型號 Model Number	馬達 Motor	最大使用壓力 Max. Pressure	輸出壓力 Pressure Rating		輸出油量 Output flow rate		重量 (含油) Weight (include oil)
			1 st stage	2 nd stage	1 st stage	2 nd stage	
SPE-200RI-	0.5(5/8)	29,000(2000)	435(30)	29,000(2000)	2	0.1	19

SPE-2000RI- 電動油壓泵浦

- 採用高效能軸心活塞式泵浦，可有效於壓力變換時減少能量損失。
- 壓力開關及安全閥，雙安全機制預防超壓使用。
- 可外部調壓，出廠已預設壓力上限確保系統超荷使用。
- 附易讀值油位計。
- 全罩式散熱馬達，可適用於戶外操作環境。

High Pressure Hydraulic Electric Pump

- ※ Pump adopting a high-performance axial piston system and greatly reducing the change in the discharge volume caused by the pressure fluctuation.
- ※ Equipped with a double safe mechanism of the safety valve and the pressure switch to prevent an overload.
- ※ User adjustable external relief valve with a factory set upper limit prevents system overload.
- ※ Easy to read integrated oil level sight glass.
- ※ Totally enclosed fan-cooled motors are ideal for outdoor use in many environments.



Model Number 型號	Motor 馬達 kW/(hp)	Insulation 絕緣	Flow Rate 輸出流量 (L/min)		Pressure Rating 輸出壓力 (bar)	Rpm 轉速		Weight (22L tank no oil) 重量 (kg)
			50Hz	60Hz		50Hz	60Hz	
SPE-2000RI2	1.5/(2)	E class Totally enclosed fan-cooled	0.35	0.42	2500	1500	1800	110
SPE-2000RI5	3.7/(5)	E級 全閉外扇	0.9	1.08		1500	1800	130

※ 型錄標示重量及尺寸為22L空油箱範例，其他油箱高度及重量依實品略有不同。
Product weight and reservoir high will be changed by different reservoir.
Catalog sample is 22L no oil reservoir.

電動泵浦基本閥型 BASIC PUMP VALVE	適用油壓缸 Used with cylinder		閥作用 Valve Function	
	↑	↓	↑	↓
手動三口方向閥 Manual 3 way Valve	●	●	●	●
手動四口方向閥 Manual 4 way Valve	●	●	●	●

SPE-2000RI-Series

Reservoir Capacity: 22L
Flow at rated pressure: 0.35-1.08 L
Motor Size: 1.5、3.7kW (2、5 hp)
Maximum Operating Pressure: 2500 bar

電泵型號選擇：Custom build your Electric Pump:

SPE-2000RI5-2 6 3 20 3

- | | |
|--|---|
| 1.馬達
2000RI2=2HP(1.5kw)
2000RI5=5HP(3.7kw) | 1.Voltage
2000RI2=2HP(1.5kw)
2000RI5=5HP(3.7kw) |
| 2.電壓
2=220V-4P | 2.Voltage
2=220V |
| 3.Hz
5=50Hz
6=60Hz | 3.Hz
5=50Hz
6=60Hz |
| 4.相數
3=3ph | 4.Phase
3=3ph |
| 5.油箱
20=20L | 5.Reservoir
22=22L |
| 6.閥門樣式
3=手動三口控制閥
4=手動四口控制閥 | 6.Valve
3=3way Manual Valve
4=4way Manual Valve |
| 7.選配
C=線控裝置
W=輪子 | 7.Optional
C=Remote control
W=Wheel |

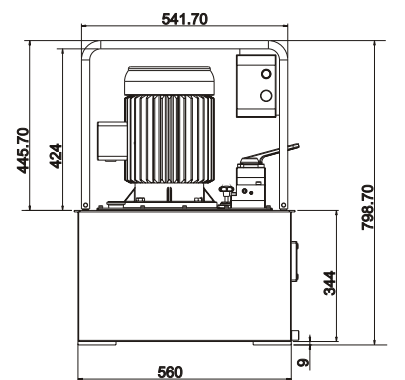
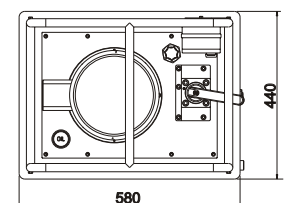

SPE-2000RI2-263223

