

SPE-2 電動油壓泵浦

- 雙速設計減少循環次數；增加效能。
- 易配合客製要求訂製。
- 可外部調壓，出廠已預設壓力上限確保系統超荷使用。
- 附易讀值油位計。
- 全罩式散熱馬達，可適用於戶外操作環境。

Hydraulic Electric Pump

- ※ Two stage models for reduced cycle times and improved productivity.
- ※ Easy to customize with modular accessory kits.
- ※ User adjustable external relief valve with a factory set upper limit prevents system overload.
- ※ Easy to read integrated oil level sight glass.
- ※ Totally enclosed fan-cooled motors are ideal for outdoor use in many environments.

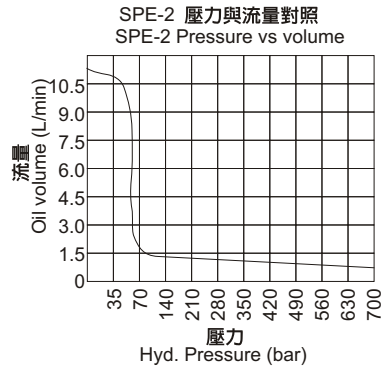

電泵型號選擇：Custom build your Electric Pump:

SPE-2 2 6 3 20 3 CW
1 2 3 4 5 6 7

- | | |
|---|---|
| 1.馬達
2=2Hp(1.5kW) | 1.Motor
2=2Hp(1.5kW) |
| 2.電壓
2=230V
3=380V | 2.Voltage
2=230V
3=380V |
| 3.Hz
5=50Hz
6=60Hz | 3.Hz
5=50Hz
6=60Hz |
| 4.相數
1=1ph
3=3ph | 4.Phase
1=1ph
3=3ph |
| 5.油箱 (Lx0.26=gal)
20=20L(5.2gal)
40=40L(10.5gal)
60=60L(15.8gal)
★亦可依客戶訂製 | 5.Reservoir (Lx0.26=gal)
20=20L(5.2gal)
40=40L(10.5gal)
60=60L(15.8gal)
★User can order suitable reservoir. |
| 6.閥
3=手動三口方向閥
4=手動四口方向閥
5=三口電磁閥
6=四口電磁閥
7=三口逆止式電磁閥
8=四口逆止式電磁閥 | 6.Valve
3=Manual 3Way
4=Manual 4Way
5=Solenoid 3way
6=Solenoid 4Way
7=Check Solenoid 3Way
8=Check Solenoid 4Way |
| 7.選配
C=線控裝置
W=輪子
G=壓力錶 | 7.Optional
C=Remote control
W=Wheel
G=Pressure gauge |

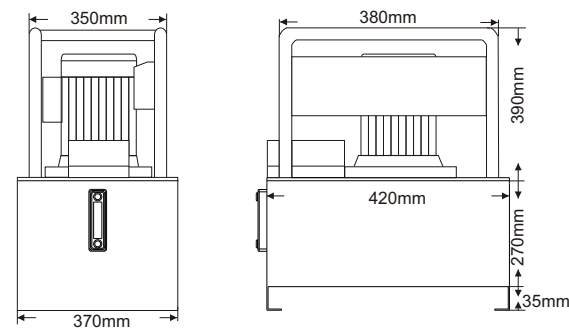
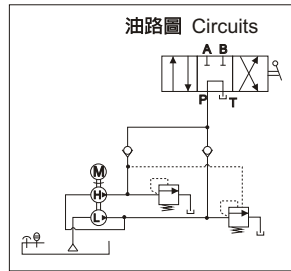

SPE-2153202

型號 Model Number	馬達 Motor kW (hp)	操作 Operation Two-stage 雙速操作	輸出壓力 Pressure Rating (bar)		輸出流量 Flow Rate (L/min)		轉速 Rpm	噪音值 dBA at Idle and 700bar	重量 Weight (20L no oil) (kg)
			1 st stage	2 nd stage	1 st stage	2 nd stage			
SPE-2	1.5 (2)	Two-stage 雙速操作	55	700	10.5	1	1725	70-79	55.5

※ 型錄標示重量及尺寸為20L空油箱範例，其他油箱高度及重量依實品略有不同。
Product weight and reservoir high will be changed by different reservoir.
Catalog sample is 20L no oil reservoir.

SPE-2 Series

Reservoir Capacity:
20-60L

Flow at rated pressure:
10.5-1 L

Motor Size:
1.5kW (2 hp)

Maximum Operating Pressure:
700 bar

SPE-5 電動油壓泵浦

- 多款油箱容量適用於各種油壓缸。
- 所有泵浦均配有堅固框架，適用於各種惡劣操作環境。
- 雙速設計減少循環次數；增加效能。
- 可外部調壓，出廠已預設壓力上限確保系統超荷使用。
- 附易讀值油位計。
- 全罩式散熱馬達，可適用於戶外操作環境。

Hydraulic Electric Pump

- ※ Vary reservoirs for use with a wide range of cylinders and application.
- ※ All pumps feature sturdy Roll Cages for use in tough environments.
- ※ Two stage models for reduced cycle times and improved productivity.
- ※ User adjustable external relief valve with a factory set upper limit prevents system overload.
- ※ Easy to read integrated oil level sight glass.
- ※ Totally enclosed fan-cooled motors are ideal for outdoor use in many environments.

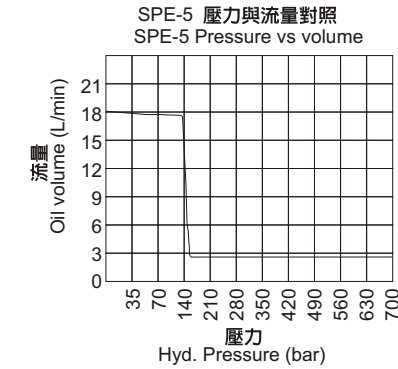

電泵型號選擇：Custom build your Electric Pump:

SPE-5 2 6 3 50 4 CW
1 2 3 4 5 6 7

- | | |
|---|---|
| 1.馬達
5=5Hp(3.7kW) | 1.Motor
5=5Hp(3.7kW) |
| 2.電壓
2=230V
3=380V | 2.Voltage
2=230V
3=380V |
| 3.Hz
5=50Hz
6=60Hz | 3.Hz
5=50Hz
6=60Hz |
| 4.相數
3=3ph | 4.Phase
3=3ph |
| 5.油箱 (Lx0.26=gal)
50=50L(13.2gal)
60=60L(15.8gal)
★亦可依客戶訂製 | 5.Reservoir (Lx0.26=gal)
50=50L(13.2gal)
60=60L(15.8gal)
★User can order suitable reservoir. |
| 6.閥
3=手動三口方向閥
4=手動四口方向閥
5=三口電磁閥
6=四口電磁閥
7=三口逆止式電磁閥
8=四口逆止式電磁閥 | 6.Valve
3=Manual 3Way
4=Manual 4Way
5=Solenoid 3way
6=Solenoid 4Way
7=Check Solenoid 3Way
8=Check Solenoid 4Way |
| 7.選配
C=線控裝置
W=輪子
G=壓力錶 | 7.Optional
C=Remote control
W=Wheel
G=Pressure gauge |

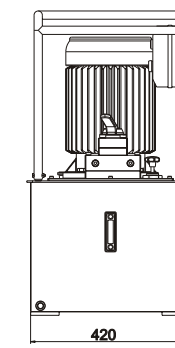
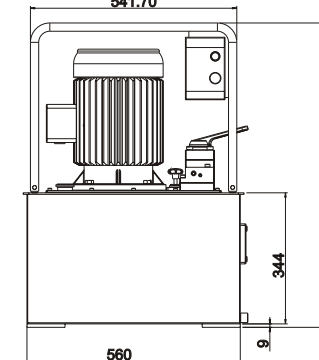
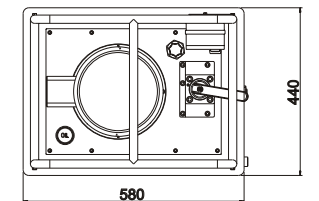
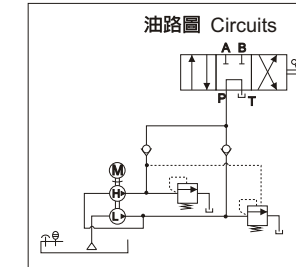

泵浦基本閥型 BASIC PUMP VALVE	適用油壓缸 Used with cylinder		閥作用 Valve Function		
	↑	↓	↑	↓	↕
手動三口方向閥 Manual 3 way Valve	●		●	●	●
手動四口方向閥 Manual 4 way Valve		●	●	●	●

型號 Model Number	馬達 Motor kW (hp)	操作 Operation Two-stage	輸出壓力 Pressure Rating (bar)		輸出流量 Flow Rate (60Hz) (L/min)		轉速 Rpm	噪音值 dBA at Idle and 700bar	重量 Weight (50L no oil) (kg)
			1 st stage	2 nd stage	1 st stage	2 nd stage			
SPE-5	3.7 (5)	雙速操作 Two-stage	60	700	18	2.6	1740	70-79	190