

LSW Series

Maximum Spread Force:
16 ton (157kN)

Min. Clearance / Max. Lift Ht.¹⁾:
9.9 / 51.3-69.1¹⁾ mm

Maximum Operating Pressure:
700 bar

¹⁾Using Stepped block SWRFSB to increase wedge lifting height 30mm.

LSW-16 油壓楔型舉升器

- 僅需0.39(9.9mm)的間隙。
- 在700bar壓力時具16ton舉升力。
- 自動機械回縮 (單動彈簧回縮)。
- 安全舉升16ton不滑落。
- 附安全墊塊 SLW-C1-16。
- 串聯使用可提升至32ton或64ton。
- 每階可垂直舉升21.1mm(選配階梯墊塊 SLW16-A07可最大舉升69.1mm)
- 每階均可承載全額定荷重。
- 獨特的連結設計，無首階彎曲及防滑設計。

Hydraulic Vertical Lifting Wedge

- ※Require 0.39" (9.9mm) access gap.
- ※Lifting force 16 ton at 700bar hydraulic pressure.
- ※Automatic mechanical retraction (single acting spring return).
- ※Securely raises or lowers 16 tons with no slippage.
- ※Lifting wedge LSW-16 includes safety block SLW-C1-16.
- ※Use in tandem to lift 32 tons, or 64 tons.
- ※21.1mm of vertical lift from each step (maximum lift to 69.1mm with optional SLW-C2-16 stepped block).
- ※Each step can spread under full load.
- ※Unique interlocking wedge design, no first step bending and risk of slipping out.

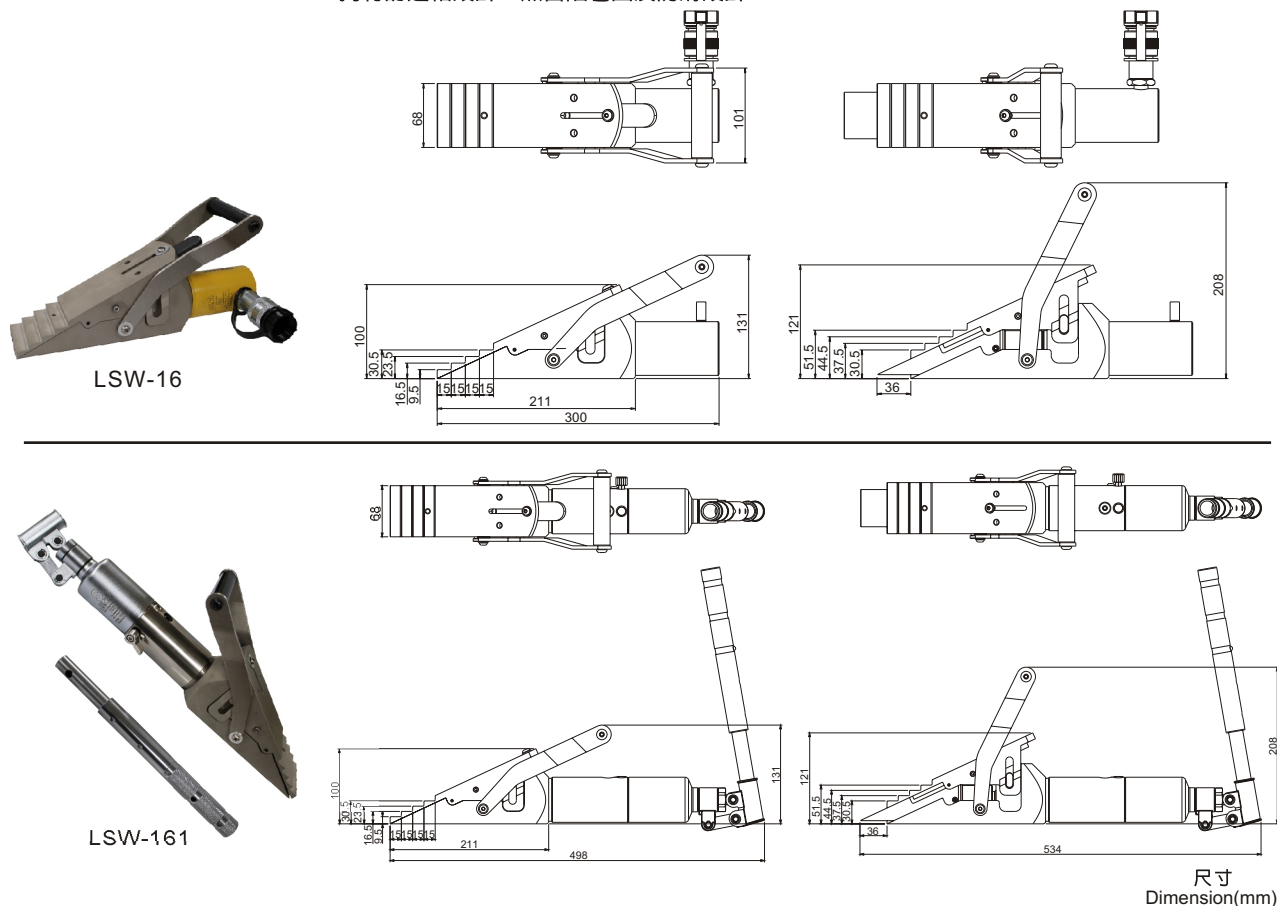

尺寸 Dimension(mm)

選配配件 Optional fitting

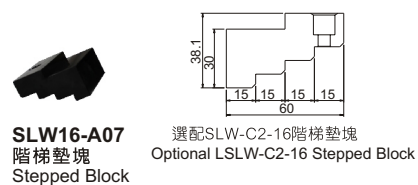

標準配件 Equipped fitting



手控分流閥
建議使用控制分流閥同步控制
2或4個楔型舉升器

Control Manifolds
Control Manifold to control two or four lifting wedges simultaneously.

型號 Model No.	最大撐開力 Max. Lifting Force ton (kN)	最小空隙 Minimum clearance Gap (mm)	每階最大舉升 Max. Lift per Stage (mm)	最大舉升高 Max. Lift Ht. (mm)	使用階梯墊塊 最大舉升高 Max. Lift Ht. Using stepped block (mm)	總油量 Oil Capacity (cc)	重量 Weight (kg)
LSW-16	16ton(157kN)	9.9mm	21.1mm	51.3mm	69.1mm	78	7
LSW-161	16ton(157kN)	9.9mm	21.1mm	51.3mm	69.1mm	152	7

SLOH 油壓側趾式千斤頂

- 用於最小頂升空間設備。
- 遠端操作液壓泵，安全性更高。
- 低高度頂升突趾。
- 精確導向減少摩擦並避免油缸偏向荷載。
- 二隻可延伸的支撐腳增加穩定性。
- 包括RSC系列油缸及SQB系列快速接頭。

Hydraulic Machine Lifts

- ※For lifting heavy equipment with minimum available access.
- ※Remote operation of hydraulic pump enhances safety.
- ※Low-height lifting toe.
- ※Precision guided to reduce friction and isolate cylinder from side-loads.
- ※Two extendable support feet provide extra stability.
- ※Includes RSC series cylinder with SQB series coupler.

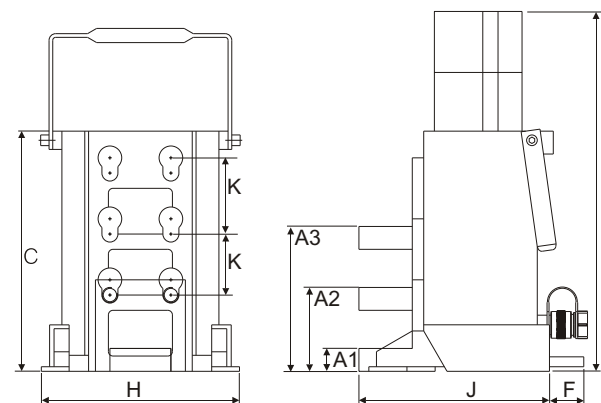

SLOH Series

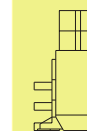

Toe Capacity:
8.5-20 ton

Stroke:
136-157-362mm

Maximum Operating Pressure:
700 bar

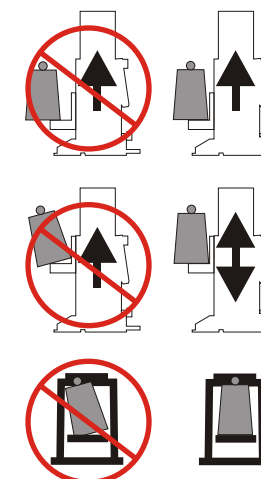
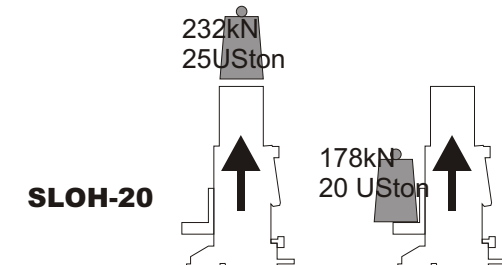
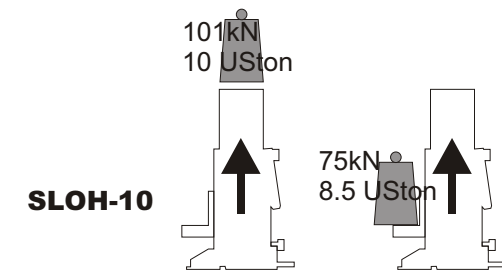

型號 Model No.	頂部荷重 Top cap. (ton)	爪部荷重 Low toe-Lift cap. tons/kN	揚程 Stroke (mm)	油量 Oil Capacity (c.c)	外型尺寸 Dimensions (mm)					突趾高度 Toe-Lift Clearance with Cyl. Retracted A1-A2-A3 (mm)	總重 Weight (kg)	最大壓力 Max. Pressure (bar)	
					本體高 Body Ht. C	伸長高 Ext. Ht. D	F	H	J				K
SLOH-10	10.0	8.5/75	136	224.5	294	430	-	190	214	74	20-95-169	26	700
SLOH-20	20.0	20/178	157	524.4	320	472	65	265	250	80	30-110-190	45	700