

SPAQH 超高壓框架型氣動泵浦

- 具三點組合、濾水調壓、自動潤滑、洩壓閥。
- 具過濾器，過濾雜質保護機體。
- 不銹鋼底座及框架。
- 便於提攜。

High Pressure Frame Air Pump

- ※ Air units (F.R.L. Unit) provide filter, regulator and lubricate.
- ※ Input filter which provide protect.
- ※ Steel base and frame.
- ※ Easy to carry.

SPAQH Series

Reservoir Capacity:
5600 c.c

Air pressure:
5-7 kgf/cm²

Maximum Operating Pressure:
1500-2400 bar

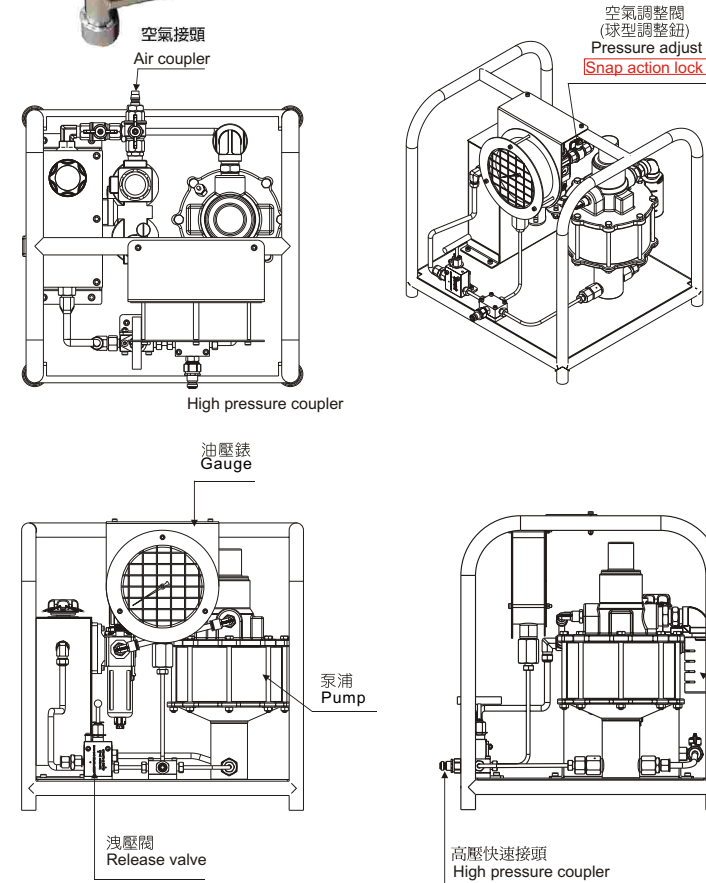

型號 Model Number	壓縮比 Compress Ratio	出油量 Output oil (cm ³ /per stroke)	工作壓力 Work press. (bar)	使用空壓 Air press. (Kgf/cm ²)	儲油箱 Equipped reservoir ★ (c.c)	重量 Weight (kg)	外型尺寸 Dimensions		
							C	D	(mm)
SPAQH-130-1500	1:310	1.2	1500	5~7	5600	25	1/4PT-19	9/16-18UNF	400*400*420
SPAQH-180-1500	1:300	5.0	1500	5~7					
SPAQH-180-2400	1:610	2.4	2400	5~7					

★ 油箱可以需求訂製 ※ Reservoir will be changed by user.
※ 重量及外型尺寸依油箱改變 ※ Weight and dimension will be changed by reservoir alter.

SPHH 超高壓手動泵浦

- 手動泵浦內含安全閥設計，避免超壓引起損壞。

High Pressure Manual Pump

※ Manual Pump include internal pressure relief valve for overload protection.

SPHH Series

Reservoir Capacity:
1200-3000 c.c

Oil displacement at max pressure:
0.7-1.2c.c

Maximum Operating Pressure:
1600-2500 bar

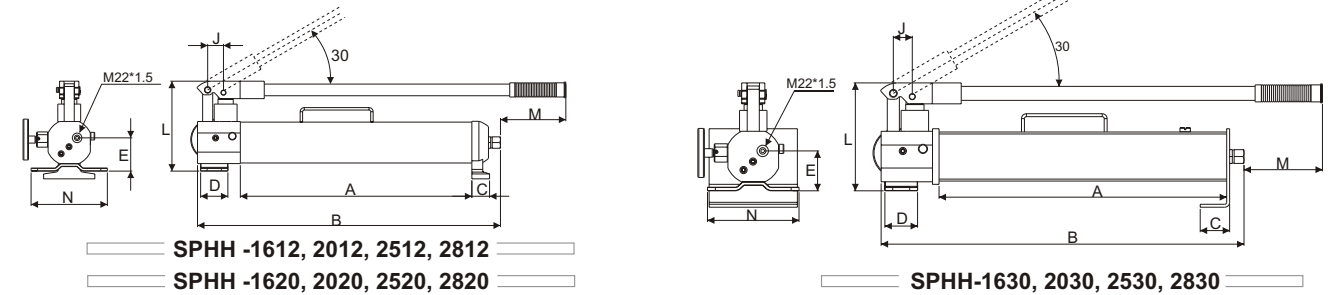
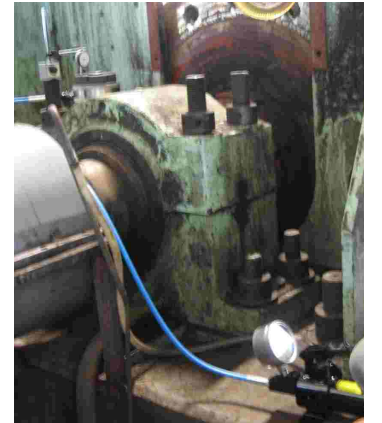
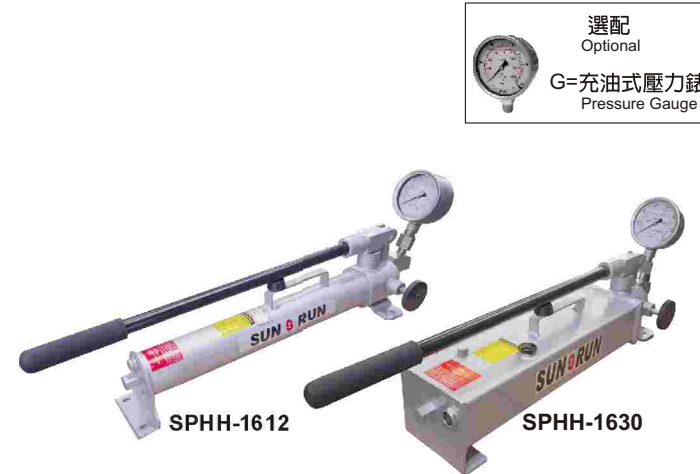

型號 Model Number	泵浦類型 Pump Type	有效油量 Usable Oil Capacity (cm ³)	輸出壓力 Pressure Rating (bar)		輸出油量 Oil Displacement per Stroke (cm ³)		行程 Piston Stroke (mm)	外型尺寸 Dimensions(mm)								重量 Weight (kg)	
			1 st stage	2 nd stage	1 st stage	2 nd stage		A	B	C	D	E	J	L	M		N
SPHH-1612	雙速 Two-Speed	1200	14	1600	15.5	1.2	16.65	425	556	32.5	50	61	29	165	120	140	9.0
SPHH-2012		1200	14	2000	15.5	0.9	16.65	425	556	32.5	50	61	29	165	120	140	9.0
SPHH-2512		1200	14	2500	15.5	0.7	16.65	425	556	32.5	50	61	29	165	120	140	9.0
SPHH-2812		1200	14	2800	15.5	0.61	16.65	425	556	32.5	50	61	29	165	120	140	9.0
SPHH-1620		2200	14	1600	15.5	1.2	16.65	425	556	32.5	50	61	29	165	120	140	11.0
SPHH-2020		2200	14	2000	15.5	0.9	16.65	425	556	32.5	50	61	29	165	120	140	11.0
SPHH-2520		2200	14	2500	15.5	0.7	16.65	425	556	32.5	50	61	29	165	120	140	11.0
SPHH-2820		2200	14	2800	15.5	0.61	16.65	425	556	32.5	50	61	29	165	120	140	11.0
SPHH-1630		3000	14	1600	15.5	1.2	16.65	440	556	45.0	50	61	29	165	120	140	13.0
SPHH-2030		3000	14	2000	15.5	0.9	16.65	440	556	45.0	50	61	29	165	120	140	13.0
SPHH-2530		3000	14	2500	15.5	0.7	16.65	440	556	45.0	50	61	29	165	120	140	13.0
SPHH-2830		3000	14	2800	15.5	0.61	16.65	440	556	45.0	50	61	29	165	120	140	13.0