

STP 油壓床

- 自動化焊接，結構强度高，耐用性佳。
- 千斤頂可左右移動，用途廣泛。
- 所有型號均含壓力錶及V型墊塊。

Hydraulic Presses

- ※ Automatic welding frame for maximum strength and long life.
- ※ Roller head design allows movement and lock the cylinder from side to side, suitable for different condition.
- ※ Gauges and V-Blocks are included on all models.

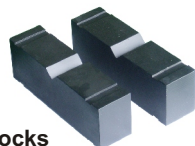

V型墊塊： V-Blocks

使用圓型或其他不規則材料時更得心應手
Design for easy fixturing of round or other nonuniform materials.

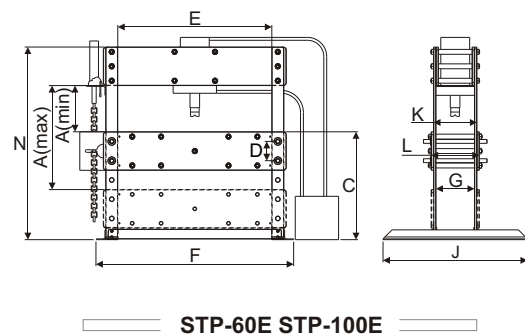
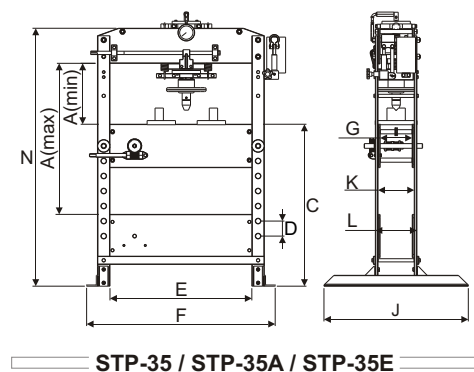
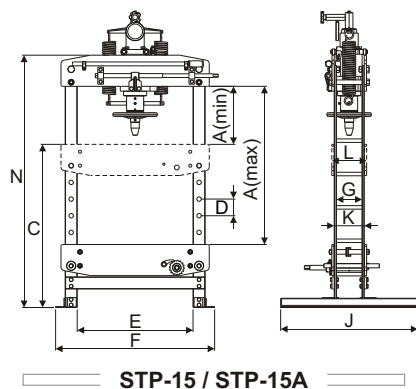

型號 Model Number	能力 Cylinder Capacity	輔助高 Screw Stroke	場程 Ram Stroke	使用壓力 Operating Pressure	幫浦樣式 Press Modal Pump ²⁾	輸出油量 Output Flow Rate	外型尺寸 Dimensions(mm)											重量 Wt. (kg)
							A (max)	A (min)	C	D	E	F	G	J	K	L	N	
STP-15	15(148)	90	108	300	H	5c.c./once	1000	310	880	90	625	858	138	740	162	188	1510	168
STP-35	35(335)	125	172	360	H	6c.c./once	1085	335	970	90	850	1130	192	865	217	249	1695	220
STP-35AH ¹⁾					A & H	750c.c./min												222
STP-35EH ¹⁾					E & H	8750c.c./min												250
STP-60E ¹⁾	60(523)	—	310	70 210	E	8750c.c./min 3000c.c./min	1050	250	1350	200	1050	1380	268	1000	306	338	1900	670
STP-100E ¹⁾	100(1010)	—	300	70 210	E	8750c.c./min 3000c.c./min	1080	480	1120	200	1600	2050	400	1500	450	500	2000	1500

1) STP-35AH : Air pressure 7~10kgf/cm² STP-35EH : 0.5HP*110/220V*1PH STP-60E : 3HP*220V*3PH STP-100E : 5HP*220V*3PH
STP-35AH : 使用空壓 7~10kgf/cm² STP-35EH : 0.5HP*110/220V*1PH STP-60E : 3HP*220V*3PH STP-100E : 5HP*220V*3PH
2) H: by manual A: by air E: by electric H / 手動 A / 氣動 E / 電動

SIP 美規油壓床

- 高強度結構、耐用度高，使用範圍廣泛。
- 液壓式平台，上下調整輕便 (10噸系列為手動式)。
- 可任意搭配使用手動、氣動、電動等動力來源。
- 所有型號均含壓力錶及V型墊塊。(10噸系列無配附V型墊塊)

Hydraulic Presses With Imperial Dimension

- ※ High strength structure and durable.
- ※ Hydraulic-lift bed for effortless adjustment in the vertical direction. (10 ton models are manual)
- ※ Multi-selection for power source, such as manual, pneumatic and electric.
- ※ Gauges and V-Blocks are included on all models.
- (Capacity 10 ton series is not equipped with V-Block)

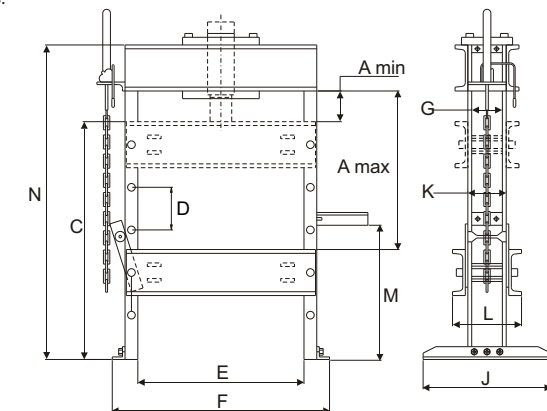

電動泵浦型號 Pump Model	馬達 Motor	油箱容量 Oil cap.
SIP-10EM	0.5hp, 115V/220V, 50/60Hz, 1ph.	3000c.c
SIP-256EM	0.5hp, 115V/220V, 50/60Hz, 1ph.	3000c.c
SIP-2514EM	1hp, 115V/220V, 50/60Hz, 1ph.	3000c.c
SIP-30EM	1hp, 115V/220V, 50/60Hz, 1ph.	3000c.c
SIP-506EM	0.5hp, 115V/220V, 50/60Hz, 1ph.	3000c.c
SIP-5013EM	2hp, 115V/220V, 50/60Hz, 1ph.	5gal.
SIP-100EM	2hp, 115V/220V, 50/60Hz, 3ph.	5gal.
SIP-150EM	2hp, 115V/220V, 50/60Hz, 3ph.	5gal.
SIP-200EM	3hp, 115V/220V, 50/60Hz, 3ph.	5gal.

壓床型號 Press Model Number	能力 Cap. ton(kN)	油壓缸型號 Cylinder Model Number	泵浦 Pump	外型尺寸 H-Frame Press Dimensions (mm)											重量 (僅框架重量) W.t (Frame W.t)	
				工作檯面高度 Vertical Daylight		C	D	E	F	G	J	K	L	M		N
				A (max)	A (min)											
SIP-RSC1010	10(101)	RSC-1010	H	1016	62	1187	127	473	632	—	756	108	189	889	1321	90
SIP-RSR1010		RSR-1010	A													
SIP-RSC256	25(232)	RSC-256	H	1384	178	1448	302	737	1029	102	762	133	272	673	1930	270
SIP-RSC2514		RSC-2514	A													
SIP-RSC308	30(295)	RSC-308	H	1384	178	1448	302	737	1029	102	762	133	272	673	1930	270
SIP-RSR3014		RSR-3014	A													
SIP-RSC506	50(498)	RSC-506	H	1233	179	1372	264	730	1086	134	914	184	365	781	1930	490
SIP-RSC5013		RSC-5013	A													
SIP-RSR5013		RSR-5013	E													
SIP-RSC10010	100(933)	RSC-10010	H	1080	178	1295	297	889	1295	171	914	222	441	842	1930	735
SIP-RSR1006		RSR-1006	A													
SIP-RSR10013		RSR-10013	E													
SIP-RSR15013	150(1386)	RSR-15013	E	1232	318	1384	254	1219	1706	232	1118	333	555	1213	2286	1960
SIP-RSR20013	200(1995)	RSR-20013	E	1232	318	1384	254	1219	1706	232	1118	333	555	1213	2286	1960

H : 手動 Hand Pumps A : 氣動 Air Hydraulic Pumps E : 電動 Electric Pumps