

## TOOLS-III 其他工具

- 提供快速安全的輪胎服務工具。
- 使用簡便，操作容易，經久耐用，加速操作流程。
- 各式手工具，油壓工具，歡迎共同開發。

## Other tools

- ※Supply fast and safely service for tire tools.
- ※Easy to use and operate, durable, simplify repair process.
- ※Supply for every kinds of hand or hydraulic tools, especially for commission.

SA-2 / SA-3



MP-110



Model Number 型號	Product Name 名稱	Cylinder Capacity 能力 (tons)	Min. Height 最低尺寸 (mm)	Max. Height 最高尺寸 (mm)	Air Pressure Rang 使用空壓 (kgf/cm <sup>2</sup> )	Weight 總重 (kg)
SA-2	氣球式千斤頂 Air jack / 2 balls type	2	130	370	5~7	14
SA-3	氣球式千斤頂 Air jack / 3 balls type	2	150	450	5~7	16

Model Number 型號	Product Name 名稱	Voltage Rating 使用電壓	Speed 速度 (mm/min)	Capacity 出力 (kgf)	Base Dimensions 底座尺寸 L x W (mm)	Weight 總重 (kg)
MP-110	避震器彈簧壓縮機 Shock absorber spring compression machine	AC110V / 1PH 220VAC	300	1500	600 X 600	70

## B 旋轉搬運小坦克

- 適用於窄小空間搬運。
- 可360°迴轉。

### Roller Skate with Turn Table

- ※Easy working in narrow space.
- ※360 degrees rotations.

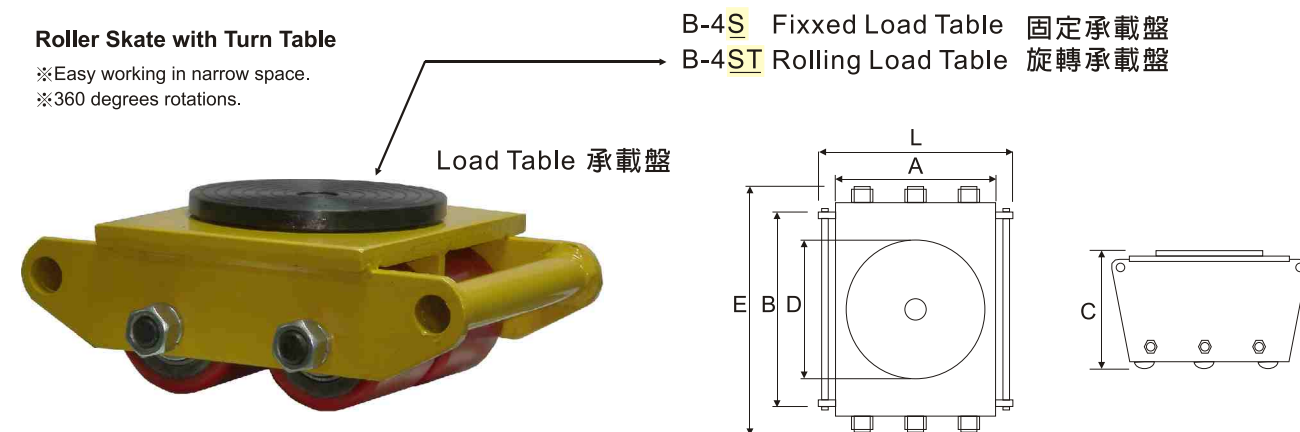

B-4S Fixed Load Table 固定承載盤  
B-4ST Rolling Load Table 旋轉承載盤

型號 Model Number	荷重 Capacity (ton)	樣式 Style	尺寸 Dimension (mm)						重量 Weight (kg)
			A	B	C	D	E	L	
B-4S	6	Pu 4wheel	170	198	110	150	218	287	15
B-4ST	6	Pu 4wheel	170	198	110	150	218	287	15
B-6S	8	Pu 6wheel	265	198	110	150	218	287	21
B-6ST	8	Pu 6wheel	265	198	110	150	218	287	21
B-8S	12	Pu 8wheel	360	198	110	150	222	477	28
B-8ST	12	Pu 8wheel	360	198	110	150	222	477	28

## JO 培林撬棒

### Bearing wrecking bar

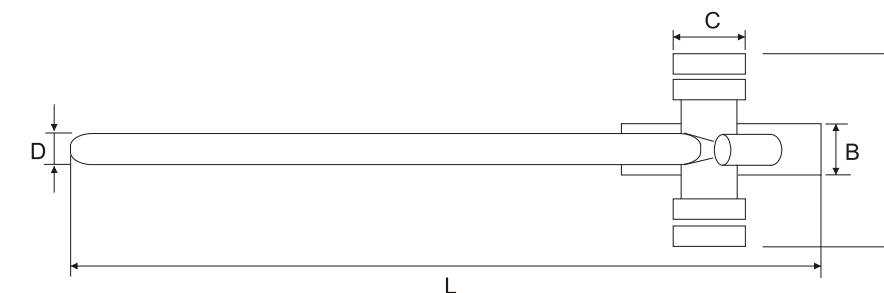

型號 Model Number	荷重 Capacity (ton)	尺寸 Dimension (mm)					重量 Weight (kg)
		A	B	C	D	L	
JO-3	3	150	65	62	34	1430	6.8
JO-5	5	165	75	72	38	1580	12.0