

ST 氣動式油壓千斤頂

- 碳鋼底座，自動化焊接，品質穩定。
- 合金鋼主軸高強度、耐荷重，表面硬鉻處理，質輕、易攜帶，具自動回縮功能。
- 各型號均附墊塊組、採用空氣動力泵浦、上昇速度快，讓工作效率更高。

Hydraulic Bottle Jack with Air Pump

- ※Carbon steel base with automatic welding makes stable quality.
- ※Chrome plated plunger with self-return resists corrosion and extends life.
- ※Fast motion by air pump design makes high efficiency.
- ※Saddle set are included on all models.

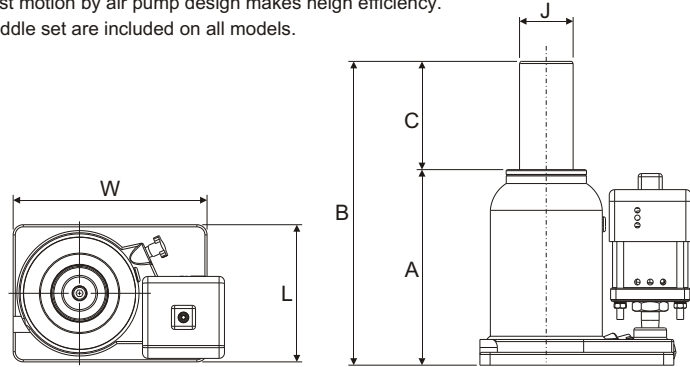

ST-series

STA-50

型號 Model Number	能力 Capacity (ton)	揚程 Stroke (mm)	本身高 Min. Height A (mm)	伸長總高 Ext. Height B (mm)	主軸直徑 Plunger Diam. J (mm)	底座尺寸 Base Dimensions L x W (mm)	輔助高 Auxiliary Height (mm)	使用空壓 Air pressure range (kgf/cm ²)	總重 Weight (kg)
ST-20H	20	344	455	799	50	128 x 181	10,45,80,160	8-12	22.0
ST-20A		150	235	385	50	128 x 181	10,45,80	8-12	16.0
ST-20B		125	210	335	50	128 x 181	10,45,80	8-12	15.0
ST-20C		100	185	285	50	128 x 181	10,45,80	8-12	14.0
ST-30A	30	145	235	380	60	141 x 197	10,45,80	8-12	22.0
ST-30B		120	210	330	60	141 x 197	10,45,80	8-12	21.0
STA-50	50	150	248	398	70	150 x 170	10,45,80	8-12	37.0

STH 手動/氣動二用型千斤頂

- 碳鋼底座，自動化焊接，品質穩定。
- 合金鋼主軸高強度，耐荷重，表面硬鉻處理，質輕、易攜帶，具自動回縮功能。
- 採空氣動力泵浦，上昇速度快，工作效率高。
- 各型號均附墊塊組。

Dual purpose Jack, Manual/ Pneumatic

- ※Carbon steel base with automatic welding makes stable quality.
- ※Chrome plated plunger with self-return resists corrosion and extends life.
- ※Fast motion by air pump design makes high efficiency.
- ※Saddle set are included on all models.

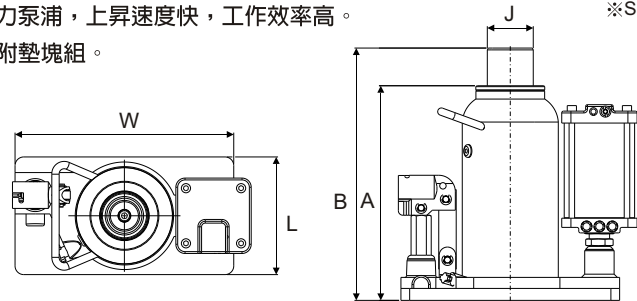

STH-20A

型號 Model Number	能力 Capacity (ton)	揚程 Stroke (mm)	本身高 Min. Height A (mm)	伸長總高 Ext. Height B (mm)	主軸直徑 Plunger Diam. J (mm)	底座尺寸 Base Dimensions L x W (mm)	輔助高 Auxiliary Height (mm)	總重 Weight (kg)	使用空壓 Air pressure Rang (kgf/cm ²)
STH-20A	20	150	235	385	50	128x238	16,45,80	14.5	8-12
STH-20B		125	210	335	50	128x238	16,45,80	13.5	8-12
STH-30A	30	145	240	385	60	141x257	16,45,80	19.6	8-12
STH-30B		120	215	335	60	141x257	16,45,80	18.6	8-12

STC 氣動式油壓千斤頂推車型

- 推車型設計使用輕便。
- 採用空氣動力泵浦、增加效率。
- 採用合金鋼主軸硬鉻處理，主軸均具自動回縮功能。
- 各型號均附墊塊組。

Air Hydraulic Truck Jack

- ※Trolley design for easy movement.
- ※Air pump increases efficiency.
- ※Chrome plated plunger with self-return.
- ※Saddle sets are included on all models.



STC-30L

STC-50DL

STC-50

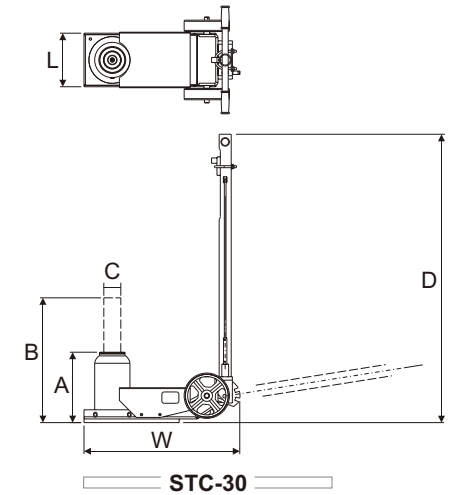

STC-30

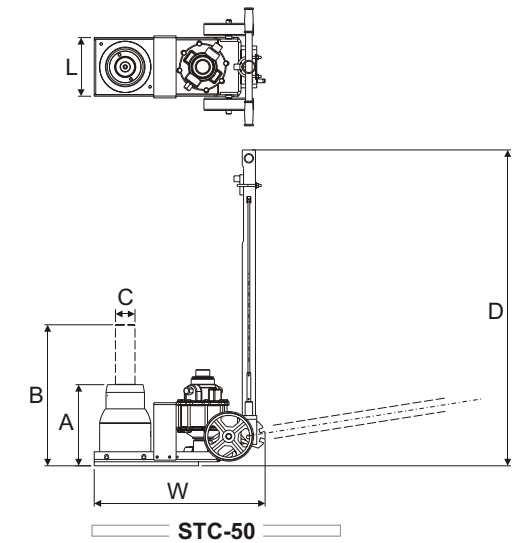

STC-50



STC-50DL

STC-50

型號 Model Number	能力 Cap. (tons)	揚程 Stroke (mm)	本身高 Coll. Height A (mm)	伸長總高 Ext. Height B (mm)	主軸 Plunger C (mm)	柄高 Handle Height D (mm)	底座尺寸 Base Dimensions L x W (mm)	輔助高度 Auxiliary Height (mm)	使用空壓 Air pressure Rang (kgf/cm ²)	總重 Weight (kg)
STC-30L	30	120	224	350	60	1385	190x570	10,45,80	10-15	45.5
STC-50	50	130	242	375	65	1055	190x570	10,60,120	10-15	58.5
STC-50L	50	130	242	375	65	1390	190x570	10,60,120	10-15	58.5
STC-50L2	50	130	242	375	65	1690	190x570	10,60,120	10-15	58.5
STC-50DL	1 st 50 2 nd 30	1 st 67 2 nd 73	160	300	∅85/∅55	1385	190x570	10,60,120	10-15	44.4
STC-50DLB	1 st 50 2 nd 30	1 st 67 2 nd 68	160	295	∅85/∅55	1385	190x821	10,60,120	10-15	58.0