

SPRE-553C 移動式拉拔器

1. 油壓舉升更易操作，精準定位拉拔器。
2. 油壓電動泵遙控操作前進、持壓和回縮。
3. 油壓拉爪設計，藉由油壓缸動作提供現場工作安全及穩固的挾持。
4. 提供方便更換二爪或三爪的設計。
5. 可搭配揚程156mm或334mm的油壓缸。
6. 油缸自動中心校正，拉爪自動平衡挾持。
7. 強力拉力及強挾持力拉爪。不需額外鏈條或覆蓋來避免拉爪滑出或彈出。
8. 拉爪具遮護功能，能保護操作者。
9. 6"萬向車輪更便於移動。

Mobile Hydraulic Pullers

1. Hydraulic lift system for easy, precise position of puller.
2. Hydraulic electric remote control advance, hold and retract.
3. Hydraulically-actuated jaws. Cylinder moves in or out to provide a safe, secure grip on workpiece.
4. Puller can be assembled in 2 or 3 jaws configurations.
5. Choice of cylinder with a 156(mm) or 334(mm) stroke.
6. Self centering: Center cylinder on work; puller jaws will automatically grip work.
7. Powerful pull and the tighter the puller jaws grip. No chains or cages required to keep puller jaws from slipping or springing off the part being pulled.
8. Guards at pinch points protect operator.
9. 6" swivel casters give ease of mobility.

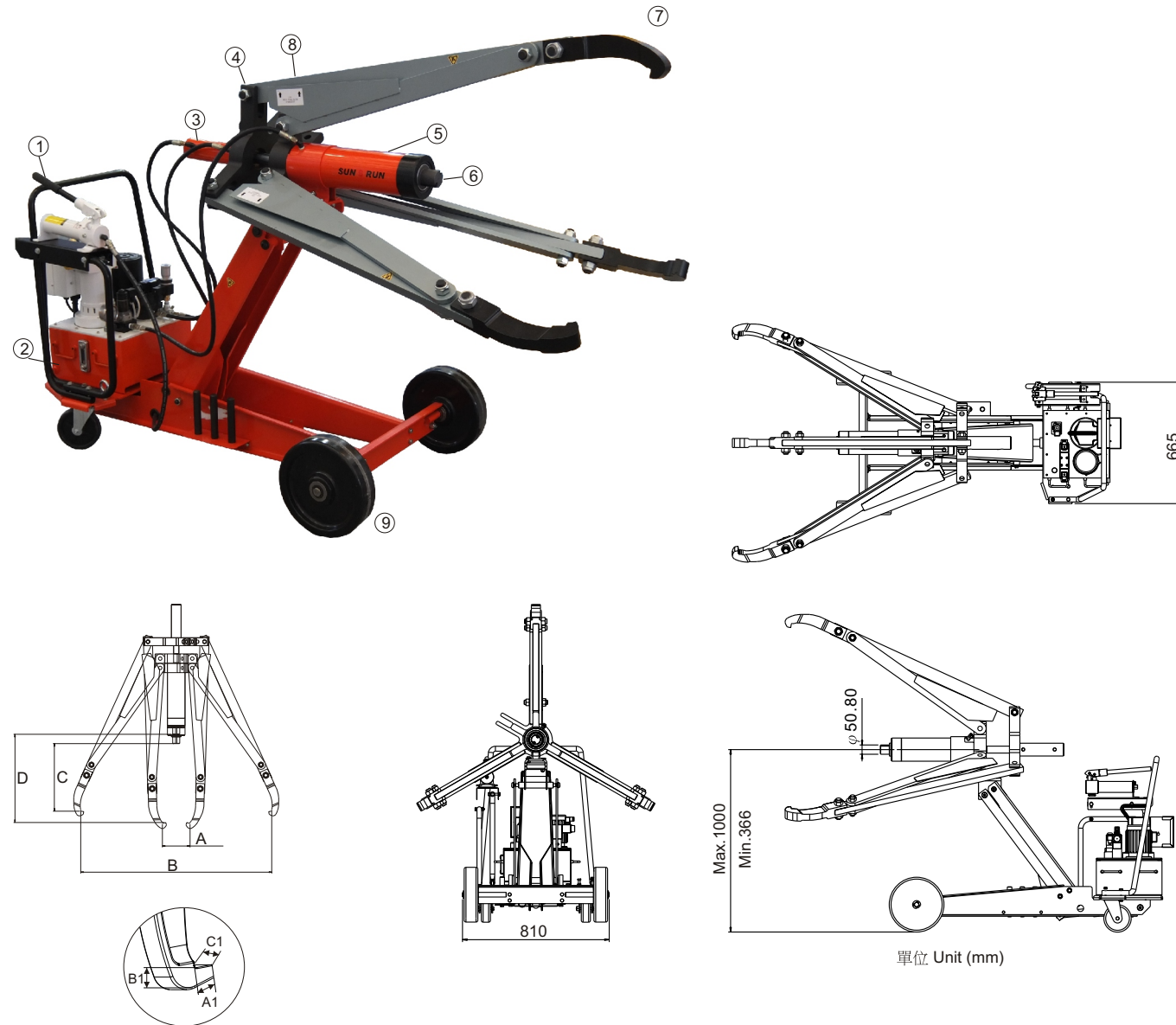

型號 Model Number	能力 Cyl. Capacity (kN)	揚程 Cyl. Stroke (mm)	爪開距離 Spread		爪深 Reach to spread		爪前鉤 Jaw Tip			重量 Wt. (kg)
			A (mm)	B (mm)	C (mm)	D (mm)	L (mm)	W (mm)	H (mm)	
			A1 (mm)	B1 (mm)	C1 (mm)					
SPRE-553C	498	334	200	1380	488	637	23.65	35.7	50	380

SPR-RSR5013E 移動式油壓拉拔器 Mobile Hydraulic Pullers

- 適用於拆卸培林、聯軸、齒輪和其他零件，更具效率和適用性。
- 移動式油壓拉拔器在機能及工效性上更形出色。
- 良好的穩定性、移動性和調整性。
- 最大撐開力50噸和最大撐開距離520mm。
- 安全及簡易的電動操作模式，附有遙控裝置、保護蓋和壓力錶更確保安全性。

- ※ It's used for dismantling bearings, couplings, gears and other parts, with relative speed and more easily.
- ※ The Mobile Hydraulic Pullers excels through functional and ergonomic operation.
- ※ It's stable, mobile and adjustable in height.
- ※ A maximum tractive force of 50 tons can be applied with diameters of up to 520 mm.
- ※ To ensure safe and easy operation the electrical models are equipped with remote control, safety cage and pressure gauge.

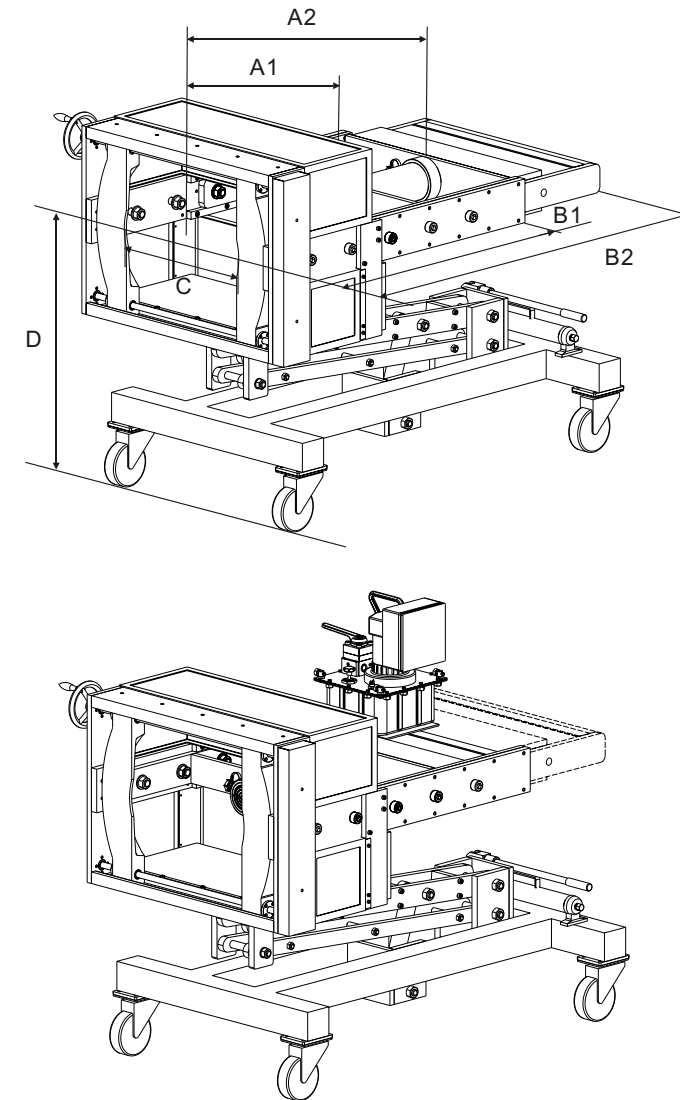

選配泵浦 Optional pump

- 手動手泵浦操作
Manual hand pump control.
- 油壓電動泵浦線控操作
Hydraulic electric pump remote control.

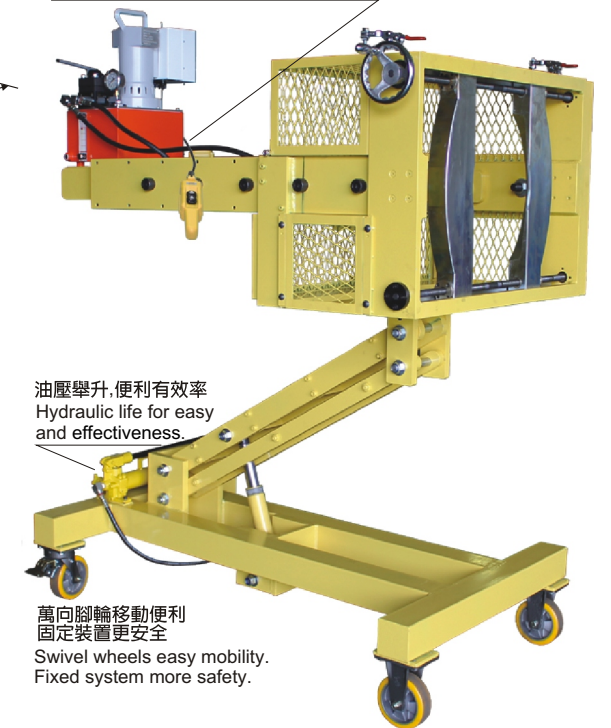

油壓舉升，便利有效率
Hydraulic lift for easy and effectiveness.

萬向腳輪移動便利
固定裝置更安全
Swivel wheels easy mobility.
Fixed system more safety.

型號 Model Number	能力 Cap. (tons)	揚程 Stroke cylinder (mm)	油壓泵浦類型 Pump hydraulic manual/electric	標準狀態 In standard position A1 (mm)	延伸狀態 In extended position A2 (mm)	框架標準狀態 Frame length in standard position B1 (mm)	框架延伸狀態 Frame length in extended position B2 (mm)	最大撐開距離 Max. Dia. C (mm)	升降高度 Set-up height D (mm)
SPR-RSR5013E	50	334	電動型雙動泵浦 Double-acting Electric Pump	790	1170	1210	1590	520	939~1469