

## SFS Series

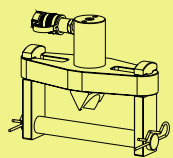

Capacity:  
**5-10 ton**

Maximum Operating Pressure:  
**700 bar**

## SFS 法蘭分離器

- 易於攜帶操作，經濟性考量設計
- 可調式尖端寬度 70 - 216mm，應用範圍廣
- 搭配單動、彈簧回縮 RSC-系統千斤頂，操作簡單、快速

### Hydraulic Flange Spreader

- ※ Lightweight, ergonomic design for ease of use.
- ※ Adjustable jaw widths from 70 - 216 mm for a wide range of applications.
- ※ Single-acting, spring return RSC-Series cylinder for fast trouble-free operation.

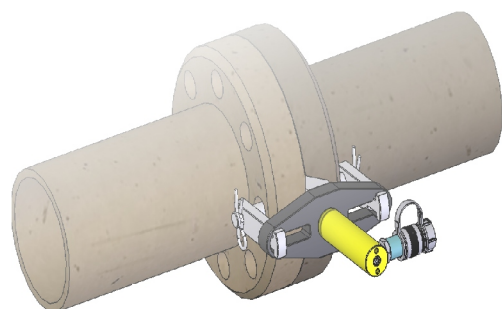

### 法蘭撐開對照表

Flange Spreader Matching Chart

ASA Rating (bar)	管尺寸 Pipe Size (mm)	
	SFS-56	SFS-109
10	127-508	558-1066
20	63-355	406-711
27	63-304	355-609
35	63-254	304-508
62	12-152	203-406
103	12-88	101-203
172	12-63	76-101

標準配件  
Equipped fitting



收納箱  
Stock Box

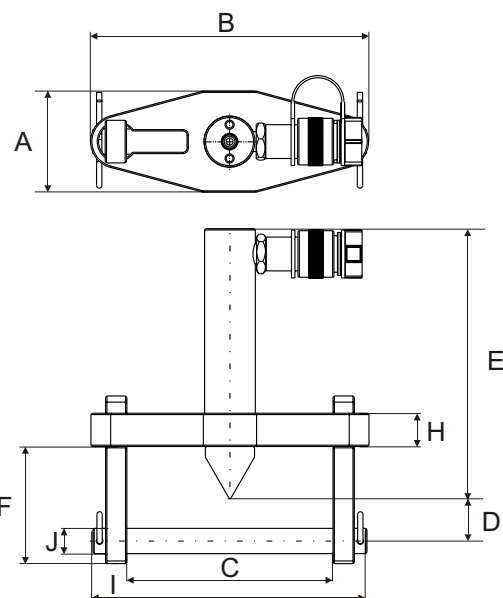

相關法蘭撐開器工具也可參考SWR-Series 移動楔獨特連結設計:無摩擦力、平滑且平行。降低法蘭和撐開臂的損壞風險。



**Wedge Spreaders**  
Friction-free, smooth and parallel wedge movement with unique interlock wedge design. Eliminates flange damage and risk of spreading arm failure.

### 法蘭撐開器選配

Flange Spreader Sets-Optional



Hydraulic Hand Pump

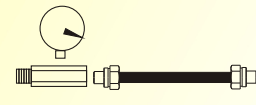

XH series GSA series XU series

型號 Model Number	能力 Capacity (ton)	揚程 Stroke (mm)	總油量 Oil Cap. (mm)	法蘭厚度 Max. Flange Thickness (mm)	螺栓尺寸 Stud Size (mm)	撐開距 Standard Wedge (mm)	尺寸 Dimensions (mm)											重量 Wt. (kg)
							A	B	C		D	E	F	H	I	J		
									Min.	Max.								
SFS-56	5	38	24.6	2 x 57	19-28	3-28	76	209	70	155	32	196	88	25	206	19	11.5	
SFS-109	10	54	78.7	2 x 92	31-41	3-28	108	279	104	216	50	152	114	38	273	31	18.1	

## SMG Series

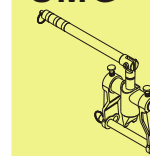

Capacity:  
**7 ton**

Spreading distance:  
**2.0-27.0mm**

## SMG 法蘭撐開器

- 適用於間隙最少在2.0mm (0.08") 較小型或較低壓的法蘭結面。
- 具有6.8T (68kN) 撐開力。
- 可反轉兩側，提供最佳使用範圍。
- 獨特的雙角度楔型設計，不因撐開距離而減少力量。

### Mini-Gap Flange Spreader

- ※ For use on smaller, lower pressure flange joints with a minimum access gap of 2.0mm (0.08").
- ※ The tool will provide 6.8T (68kN) of spreading force.
- ※ Reversible leg design giving greater range of applications.
- ※ Unique double angled wedge produces great spreading force without reducing spreading distance.
- ※ Robust lightweight tool.



Equipped fitting  
標準配件

收納箱  
Stock Box

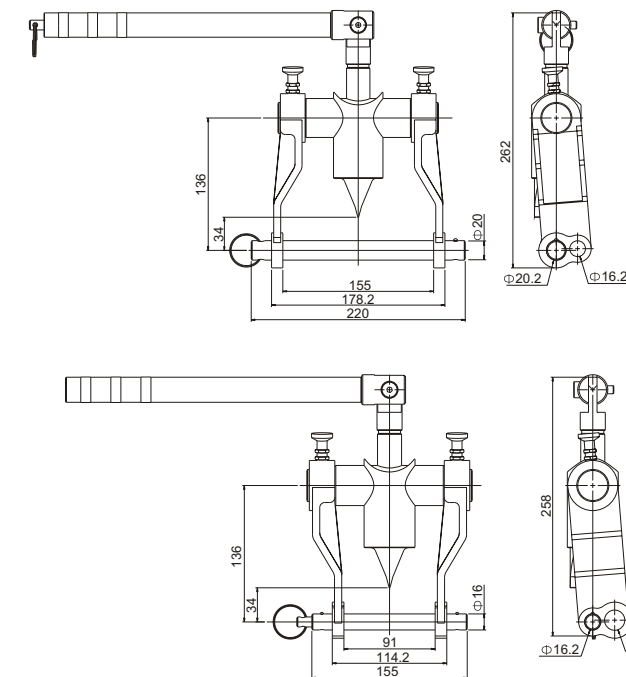

型號 Model Number	能力 Capacity (kN/ ton)	撐開距離 Spreading distance (mm)	重量 Wt. (kg)	適用範圍 Range of application											
				BS10 Flanges		ASME B16.47 Flanges (含焊頸及盲通) (Including weld neck and blind flange)		ASME B16.5 Flanges (焊頸) (weld neck)		ASME B16.5 Flanges (焊槽) (Socket welded)		ANSI reducing application Flanges (含牙及滑道) (Including threaded and slip on flange)		ANSI orifice application Flanges (含焊頸、牙及滑道) (Including weld neck, thread and slip on flange)	
				等級 Class	範圍 Range	等級 Class	範圍 Range	等級 Class	範圍 Range	等級 Class	範圍 Range	等級 Class	範圍 Range	等級 Class	範圍 Range
SMG-7TM	68/ 7	2.0-27.0	11.5	H	0.5~24"	150	26~60"	150	2~48"	150	2~3"	150	2~48"	300	1~20"
				J	0.5~24"	300	26~60"	300	3/4~48"	300	3/4~3"	300	3/4~48"		
				K	0.5~20"										
				R	0.5~20"										
				S	0.5~16"										
T	0.5~13"														