

RSRH Series

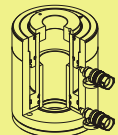

Capacity:	30-145 ton
Stroke:	38-258 mm
Center Hole Diameter:	33.3~79.5 mm
Maximum Operating Pressure:	700 bar

RSRH 液壓雙動，中空型千斤頂

- 中空柱塞設計，適用於推力及拉力之應用。
- 安全閥設計防止超壓損壞。
- 液壓缸在最大行程亦能承載最大荷重。
- 外螺牙便於固定(除RSRH-1001及RSRH-1508)均附螺牙保護套。
- 特製中空襯管保護主軸及液壓缸內壁增加產品壽命。
- 主軸硬鉻處理耐磨防腐蝕。
- 防塵環設計可保護活塞、內徑及襯管避免污染。
- 上螺帽保護主軸超揚昇。
- 表面粉體塗裝美觀抗腐蝕、防銹。
- 各型號均含SQB-3/8UF快速接頭及防塵蓋。

Double-Acting, Hollow Plunger Cylinders

- ※Hollow plunger design allows for both pull and push forces.
- ※Relief valves protect against over pressurizing.
- ※Withstands full "dead-end" loads.
- ※Collar threads for easy fixturing(Except RSRH-1001 & RSRH-1508) and all collar threads have a cap for protection.
- ※Special center tube protect plunger and inner of cylinder increases product life.
- ※Hard chrome plated plunger resists wear and corrosion.
- ※Wiper rings protect the piston, bore & tube from contamination.
- ※Stop ring for piston blow-out protection.
- ※Powder coat finish for increased corrosion resistance and antirust.
- ※Come with SQB-3/8UF female coupler & dust cap.

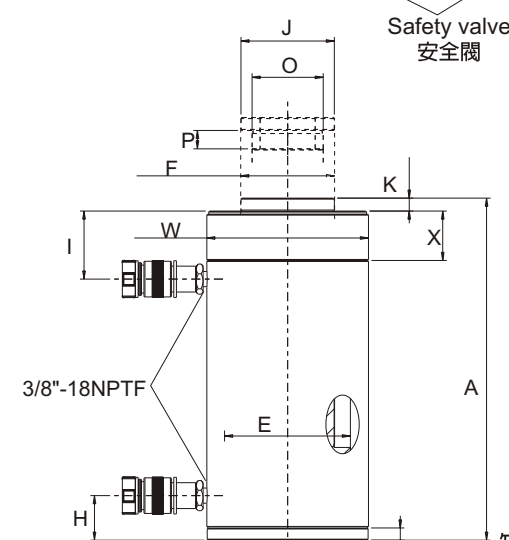
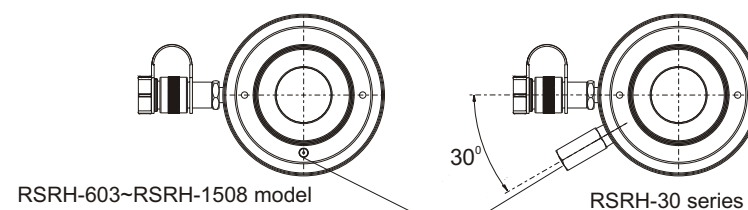

缸底墊塊 Steel baseplate :
 12ton serial : 8mm
 20~30ton serial : 10mm
 60ton serial : 12mm
 100ton serial : 16mm

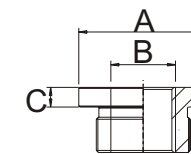

缸底墊塊前底座螺孔圖示
 This drawing show the base mounting holes of barrel before setting steel base plate.



液壓泵浦 Pump Selection
 雙動液壓千斤頂必須搭配具 4 口閥門的液壓泵浦。
 A double-acting cylinder must be powered by a pump with a 4-way valve.

油壓缸 型號 / 能力 Cylinder Model/Cap. ton(kN)	型號 Model Number	墊塊尺寸 Saddle Dimensions		
		A (mm)	B (in)	C (mm)
RSRH-307,3010	XKHCH-30	63	1-1/4"-7	9
RSRH-603,606,6010	XKHCH-60	91	1-5/8"-5-1/2	12
RSRH-1001,1003 1006,10010	XKHCH-100	126	2-1/2"-8	13

※ 所有 RSRH 系列千斤頂標準配置平滑中孔墊塊
 ※ Smooth hollow saddles are standard on all RSRH series.



請勿調整安全閥壓力!

適用於雙動千斤頂
 RSR, RSRH, CSLRG 系列
 大部份的雙動千斤頂安全閥壓力設定值為 10000psi(700bar)。
 超出原廠設定值時，安全閥會噴出液壓油保護千斤頂。
 當安全閥發生漏油狀況時請先檢查快速接頭連接狀況。

Don't adjust safety valve pressure!

Apply to double-acting cylinder
 RSR, RSRH, CSLRG series
 Most double-acting cylinder safety valve pressure setting 10000psi(700bar).
 As surpasses the original factory hypothesis pressure safety valve will spurt oil to protect cylinder.
 Leaking from safety valve, inspect connection of coupler at first.

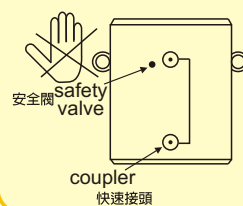

	焊提把 Weldable
	吊環螺栓 Eyebolt
	活動提把 Removable strap handles
	螺牙式活動提把 Thread

提把型式 Handle type	
(S) : 標準配件 standard equipped	
(O) : 選配 option	
● 焊提把 Weldable	
★ 吊環螺栓 Eyebolt	
▲ 活動提把 Removable strap handles	
■ 螺牙式活動提把 Thread	

提把型式 Handle type	型號 Model Number	外部尺寸 Outer Dimension										
		能力 Cylinder Capacity	揚程 Stroke	最大出力 Max. Cylinder Capacity		受壓面積 Cylinder Effective Area		總油量 Oil Capacity		本身高 Coll. Height	伸長總高 Ext. Height	外徑 Out. Diam.
				推 Push	拉 Pull	推 Push	拉 Pull	推 Push	拉 Pull			
(S)		ton(kN)	(mm)	(kN)		(cm ²)		(cm ³)		A (mm)	(mm)	D (mm)
▲	RSRH-307	30(326)	178	326	213	46.6	30.4	829	541	330	508	114
▲	RSRH-3010		258	326	213	46.6	30.4	1202	784	431	689	114
▲	RSRH-603	60(576)	96	576	380	82.3	54.2	733	482	247	343	159
▲	RSRH-606		166	576	380	82.3	54.2	1366	900	323	489	159
▲	RSRH-6010		257	576	380	82.3	54.2	2115	1393	438	695	159
▲	RSRH-1001	95(931)	38	931	612	133.0	87.4	505	333	165	203	212
▲	RSRH-1003		76	931	612	133.0	87.4	1011	666	254	330	212
▲	RSRH-1006		153	931	612	133.0	87.4	2035	1337	342	495	212
▲	RSRH-10010		257	931	612	133.0	87.4	3420	2246	460	717	212
▲	RSRH-1508		145(1429)	203	1429	718	204.1	102.6	4144	2083	349	552

外部尺寸 Outer Dimension							牙紋尺寸 Threads Dimension					底座螺孔 Base Mounting Holes			總重 Weight
內徑 Cyl. Bore Diam.	主軸直徑 Plngr. Diam.	底部前進油孔位置 Cyl. Base to Adv. Port	頂部回油油孔位置 Cyl. Top to Return Port	墊塊直徑 Saddle Diam.	凸出高度 Saddle Protr. Fr. Plngr.	主軸內牙 Plunger Internal Thread	內牙深度 Plunger Thread Length	油缸外牙 Collar Thread	外牙長度 Collar Thread Length	中孔直徑 Center Hole Diam.	底孔孔距 Bolt Circle	底座螺紋 Thread	螺紋深度 Thread Depth		
E (mm)	F (mm)	H (mm)	I (mm)	J (mm)	K (mm)	O (in)	P (mm)	W (in)	X (mm)	Y (mm)	U (mm)	V (in)	Z (mm)		
88.9	63.5	25	60	63	9	1 ¹³ / ₁₆ "-16	22	4 ¹ / ₂ "-12	42	33.3	92.2	3/8"-16	15.7	21.65	
88.9	63.5	25	60	63	9	1 ¹³ / ₁₆ "-16	22	4 ¹ / ₂ "-12	42	33.3	92.2	3/8"-16	15.7	27.65	
123.9	92.2	31	66	91	12	2 ³ / ₄ "-16	19	6 ¹ / ₄ "-12	48	54.1	130.0	1/2"-13	14.0	29.60	
123.9	92.2	31	66	91	12	2 ³ / ₄ "-16	19	6 ¹ / ₄ "-12	48	54.1	130.0	1/2"-13	14.0	36.60	
123.9	92.2	31	66	91	12	2 ³ / ₄ "-16	19	6 ¹ / ₄ "-12	48	54.1	130.0	1/2"-13	14.0	46.60	
165.1	127.0	38	44	126	12	4"-16	25	—	—	79.5	177.8	5/8"-11	19.0	36.60	
165.1	127.0	38	85	126	12	4"-16	25	8 ³ / ₈ "-12	60	79.5	177.8	5/8"-11	19.0	64.60	
165.1	127.0	38	85	126	12	4"-16	25	8 ³ / ₈ "-12	60	79.5	177.8	5/8"-11	19.0	82.60	
165.1	127.0	38	85	126	12	4"-16	25	8 ³ / ₈ "-12	60	79.5	177.8	5/8"-11	19.0	109.60	
190.5	152.4	38	60	127	4	4 ¹ / ₄ "-12	25	—	—	79.5	214.0	5/8"-11	15.0	116.00	