

SWR&SWRM Series

Maximum Spread Force:
14 ton

Tip Clearance / Max. Spread:¹⁾
6 / 81 mm

Maximum Operating Pressure:
700 bar

1)Using Stepped block.

SWR-40 & SWRM-8 法蘭撐開器 Hydraulic Spreader

- 僅需0.24(6mm)的間隙。 ※Only requests an access gap of 0.24" (6mm).
- 自動回縮。 ※Automatic mechanical retraction.
- 獨特連結設計：無首階彎曲及防滑設計。 ※Unique interlocking: no first step bending and risk of slipping out of joint.

型號 Model No.	最大撐開力 Max. Spread Force ton (kN)	尖端空隙 Tip clearance mm	最大撐開 Max. Spread mm	總油量 Oil Capacity c.c	重量 Weight kg
SWR-40	14 (125)	6	81	78	7.1
SWR-401	14.5 (145)	6	81	152	8.0
SWRM-8	8 (72)	6	81	-	6.5

尺寸
Dimension(mm)



SWR-40

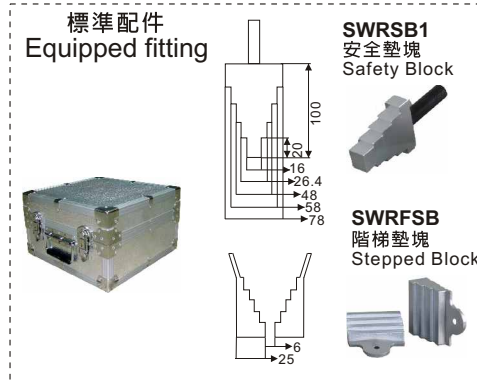
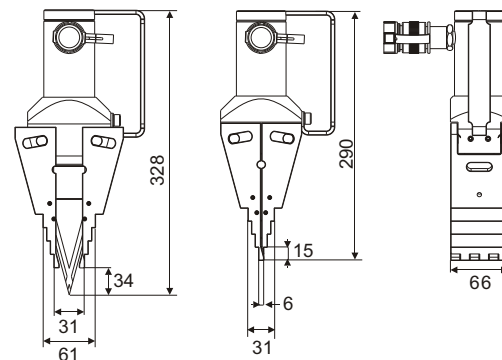

SWRM-8

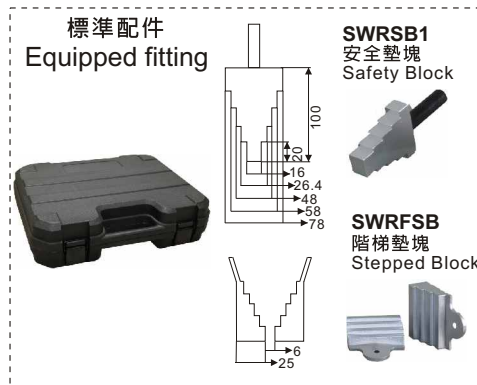
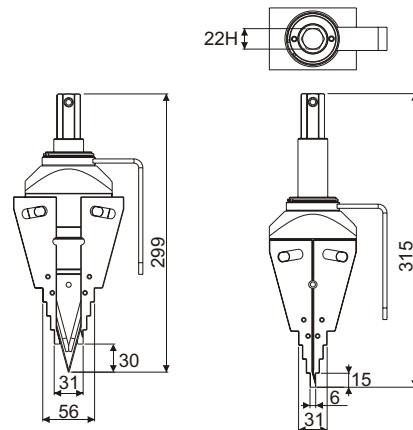

SWR-401

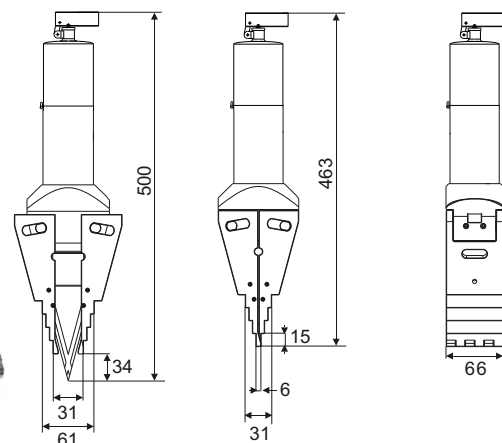

SWR系列簡易安裝示意圖 Simple Install for SWR series



手控分流閥
可同步並使SWR-40呈180°分散於法蘭結位置
For simultaneously and even spreading of flange joints, 180° apart with SWR-40

法蘭撐開組-建議選配 Flange Spreader Sets-Optional

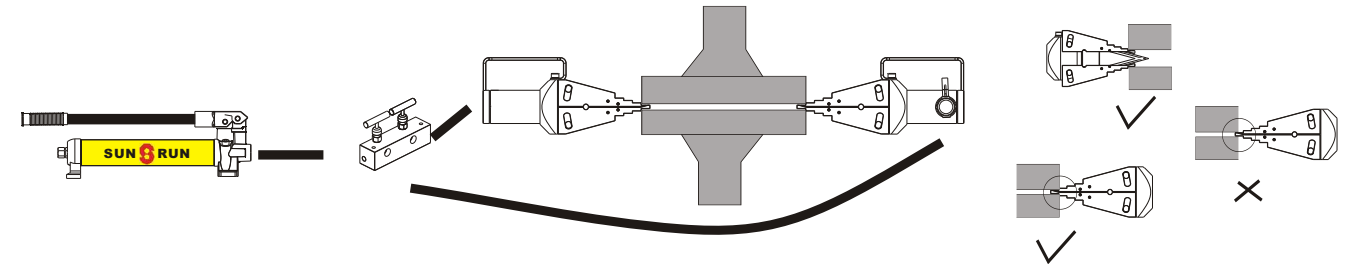
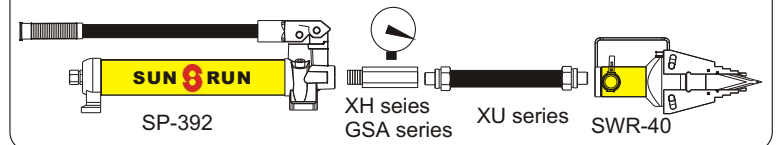

SWF-5 法蘭撐開器 Hydraulic Spreader

- 平行切口。 ※Jaws open parallel.
- 完全金屬結構。 ※Complete metal structure.

型號 Model No.	能力 Capacity	撐開距離 Spread (Min./Max.)	總油量 Oil Capacity	重量 Weight
SWF-5	5 ton	23/76mm	81.9cm ³	6.2kg
SWF-10ST	10 ton	3.7/103.7mm	160cm ³	6.35kg

SWF Series

Capacity:
5 ton

Tip Clearance / Max. Spread:¹⁾
23 / 76 mm

Maximum Operating Pressure:
700 bar

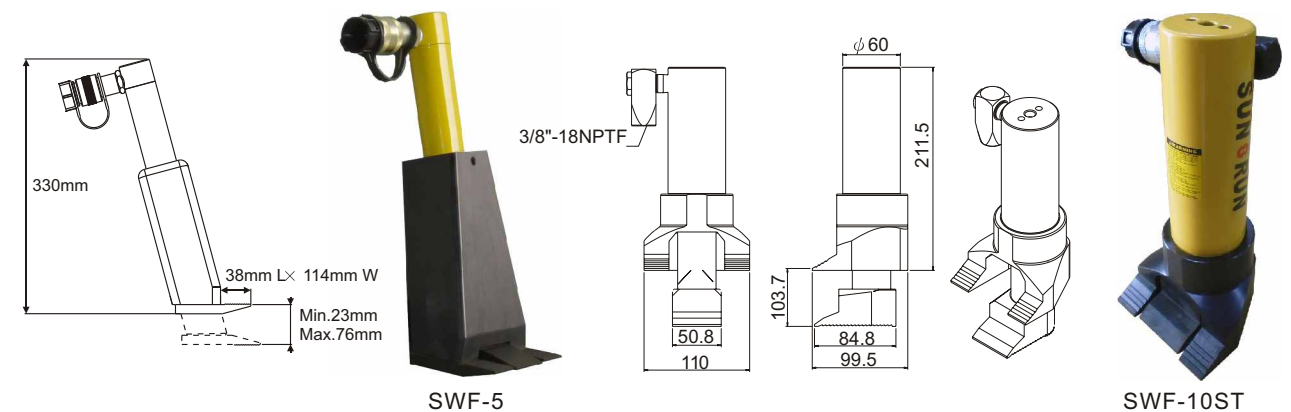

法蘭撐開組-建議選配 Flange Spreader Sets-Optional

